

1

- Using a 38mm hole saw, cut a neat hole through the benchtop.
- Screw the Threaded Rods tightly into the base of the Mixer.
- Fit the Dress Ring and O-Ring at the base of the Mixer.
- Place the Mixer over the hole and lower into position.

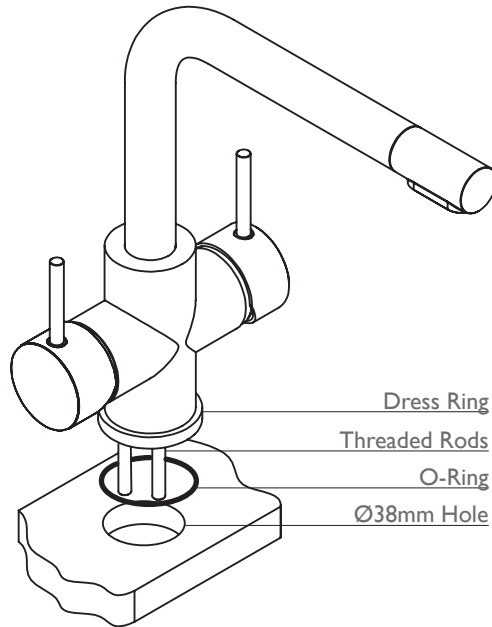

IMPORTANT

This Mixer requires mains HOT and COLD, plus an additional COLD water connection for the Filtered Water Cartridge Kit. Ensure Mixer is installed and connected to mains water supply prior to connecting the Filtered Water Cartridge Kit.

2

- Slide the Rubber Gasket and Mounting Plate over the Threaded Rods.
- Fit the Locknuts on each Threaded Rod and firmly tighten using the Spanner provided.
- Connect Filtered Water Hose to mixer first.
- Connect the Hot and Cold Water Hoses to the Mixer and Mains connection.

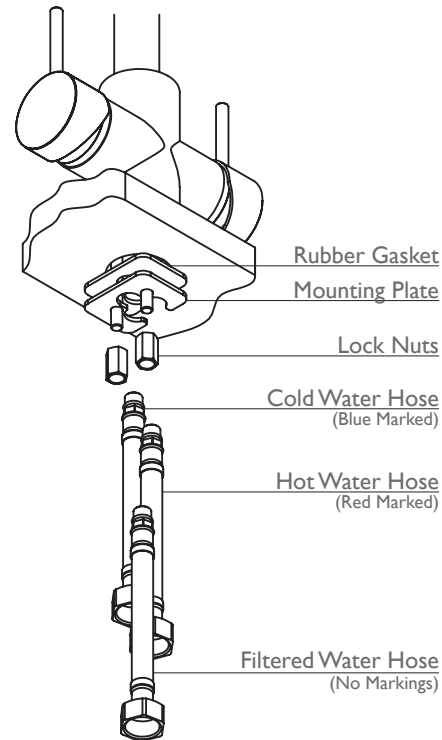

3

- Connect to Filtered Water Cartridge Kit.

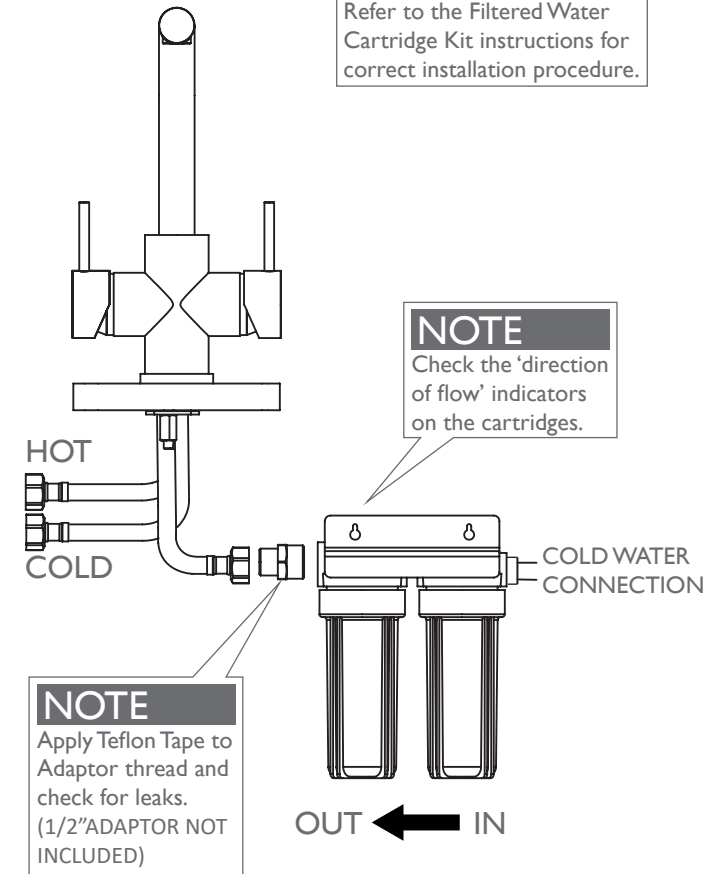

IMPORTANT
 Refer to the Filtered Water Cartridge Kit instructions for correct installation procedure.

NOTE
 Check the 'direction of flow' indicators on the cartridges.

NOTE
 Apply Teflon Tape to Adaptor thread and check for leaks. (1/2" ADAPTOR NOT INCLUDED)



recommended working pressure
150-500KPa
 maximum hot water temperature
75 degrees

NOTE:

- If the pressure exceeds or is likely to exceed 550kpa, an approved pressure limiting device must be installed.
- Flush out all pipe work prior to installation.
- If the water temperature exceeds 75°C, an approved tempering valve must be fitted.
- Installation should comply with Australian standard AS3500.1 or relevant local authority requirements. Showers may not be suitable for use within:
 - Gravity-fed water systems
 - Some instantaneous hot water systems; or

- Pressure supply less than 150kPa; NOTE: The 500kPa maximum water supply pressure does not apply to fire service outlets.

Any flow controller incorporated in the outlet to be tightened to prevent removal by hand. As Per AS3718

Failure to comply with the above may void all warranties.

WARRANTY:

Please refer to the full warranty statement enclosed with the product before installing.

MAINTENANCE AND CARE:

- Chrome plated surfaces should be cleaned with mild liquid detergent or soap and water.
- Do not use cream cleaners or citrus based cleaning products, as they are abrasive.
- Use of unsuitable cleaning agents may damage the surface. Any damage caused in this way will not be covered by warranty.

DISCLAIMER:

While we aim to ensure the specifications shown are correct at the time of printing, we reserve the right to make modifications without prior notice. Always use the physical product measurements for mark-ups and roughing-in as the line drawing shown may differ from the actual product over time.

*All measurements are shown in millimeters.