

MICRON WH303

TRIPLE WHOLE HOUSE FILTRATION SYSTEM

General Information

The WH303 Triple Whole House Filtration System is a Point of Entry Filtration System with a durable stainless steel mounting bracket, providing dependable, general-purpose filtration for your entire home or business.

Engineered for mains water supplies, it provides clean water filtered down to 5 microns, effectively reducing sediment, chlorine, and chlorine by-products such as THMs and VOCs—enhancing both taste and odour. Featuring a carbon block PFAS reduction filter, the system also targets PFAS “Forever Chemicals”, offering added protection against emerging contaminants in your water supply.

The WH303 System is ideal for budget-conscious households, featuring a specialised seal design that prevents water bypass, ensuring complete media contact for reliable, great-tasting water throughout your home.

For mains water supply.



Features and Benefits

- High flow triple filtration for both commercial and residential use
- Featuring a specialised seal design that prevents water bypass, ensuring complete media contact
- Standard size 4.5" x 20" housings — providing 100% more capacity than 4.5" x 10"
- Greater contact time, flow rates, longevity and chemical removal
- Suitable for small to large homes with 2 or more bathrooms
- 5 micron Sediment Pre-Filter removes larger particles like sand, dirt, rust, and debris from the water
- This system utilises a dual carbon configuration, incorporating a specialised carbon block designed for PFAS reduction, while also effectively reducing chlorine, THMs, VOCs, improving taste and odour
- Stainless Steel mounting bracket
- Brass thread connection
- ¼" top mount pressure gauge ports and bleed valve

Cartridge Replacement and Timeframe Suggestions

WH20-5SED 5 micron PP Sediment Filter cartridge to be replaced every 6 - 12 months.

WH20-GAC Granular Activated Carbon Filter to be replaced every 6 - 12 months.

WH20-PFAS CTO Coconut Shell Carbon Block PFAS Reduction Filter to be replaced every 6 - 12 months.



MICRON WH303

TRIPLE WHOLE HOUSE FILTRATION SYSTEM

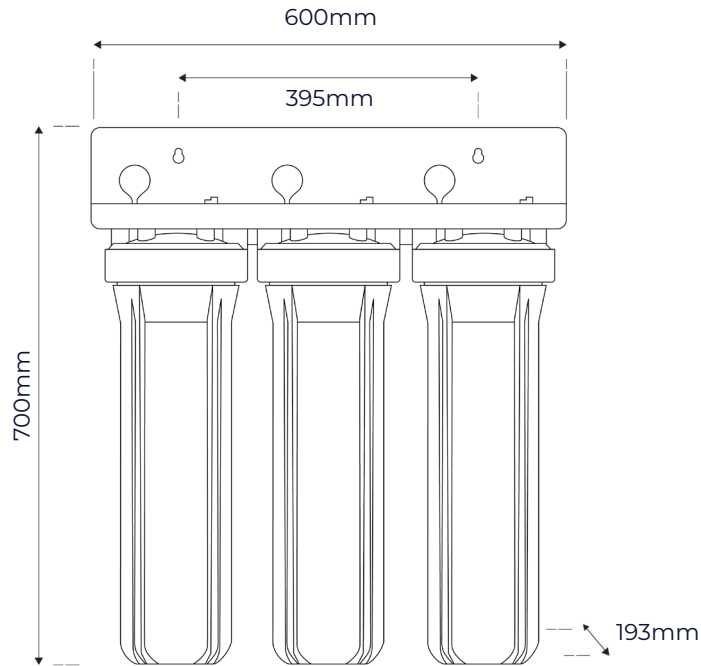

Measurements in millimetres

Triple Whole House Filtration Specifications

Model	WH303
Product Description	Triple Whole House Filtration System 1st stage: 5 micron PP Sediment pre-filter (Model: WH20-5SED) 2nd stage: Granular Activated Carbon filter (Model: WH20-GAC) 3rd stage: CTO Coconut Shell Carbon Block PFAS Reduction Filter (Model: WH20-PFAS)
Filtration Capacity	Removes dirt, sand, silt, rust and fine particles to nominal size. Reduces chlorine, PFAS, VOCs, chemicals, odour and unpleasant taste
Flow Rate	35L/min
Micron Rating	5 micron*
Min/Max Pressure	200-1600 kPa
Min/Max Temperature	4 - 42°C (must not freeze / cold water only)
Connection	Standard Port Size 1" - Brass Thread
External Cover	Stainless Steel mounting bracket
Cartridge Size	4.5" x 20"
Compatible Filter Cartridges	WH20 Series
Dimensions	700 mm (H) x 600 mm (L) x 193 mm (W)
Certification	WaterMark
Warranty	3 Years [^]

[^] 3 year warranty covering parts only, excluding cartridges. Use only genuine Micron Water Filters cartridges. Filter replacement timeframes are guidelines only and may vary with water quality and usage.

* Micron rating is nominal.