

Installation, Maintenance and Repair Manual

Flomatic Plus



Lead Free

Device: AS/NZS 2845.1 WM22155

Ball Valves: WMTS-012 WM26080

Reduced Pressure Zone (RPZ) Assemblies DN15-50mm (½" – 2")

⚠ WARNING



Read this manual **BEFORE** using this equipment. Failure to read and follow all safety and operation information can result in death, serious personal injury, property damage, or equipment damage. Keep this manual for future reference.



⚠ WARNING

Local building or plumbing codes may require modifications to the information provided. You are required to consult the local building and plumbing codes prior to installation. If this information is not consistent with local building or plumbing codes, the local codes should be followed.

⚠ WARNING

The device should be installed by authorised personnel only, subject to local regulatory authority requirements, the National Construction Code Volume Three-Plumbing Code of Australia, AS/NZS 3500 and applicable reference standards.

The device must be tested at initial installation, after maintenance and at a frequency of at least once per year according to AS/NZS 2845.3 and local regulatory authority requirements.

Corrosive water conditions and/or unauthorized adjustments or repair could render the product ineffective for the service intended. Regular checking and cleaning of the product's internal components helps assure maximum life and proper product function.

The device should be installed with adequate clearance and easy accessibility for testing and maintenance, and must be protected from submerging and freezing.

For Australia and New Zealand, line strainers should be installed between the upstream shutoff valve and the inlet of the backflow preventer. The strainer should not be fitted in fire systems which have infrequent use.

Fittings such as end connectors intended to join alternative pipe systems made from other materials (such as plastics) shall also conform to the relevant dimensional and performance requirements of the appropriate Australian, New Zealand, or joint Australian/New Zealand Standard for the alternative pipe system.

NOTICE

This product complies with the lead-free requirements of the National Construction Code Volume Three. The wetted surface area in contact with drinking water has a weighted average lead content of no more than 0.25% according to NSF/ANSI 372.



DN25 RPZ with Lockable Ball Valves and Strainer
PP-FLO-RPZ-025-ULBS

Overview

The Flomatic Plus Pressure Zone (RPZ) Devices can be used in a variety of installations to prevent high risk cross-connections in piping systems or containment at the service line entrance. It has been designed to protect potable water supplies in accordance with national plumbing codes and water authority requirements. For technical assistance, contact your local Watts representative.

Features

- DN15-50mm sizes (1/2"-2") to suit wide range of installations
- Lead-free materials for safer water (NCC Vol 3)
- Interchangeable union ball valve and strainer combinations
- Reduce assembly time and leak points with combined ball valve and strainer
- Lightweight and compact construction for easy installation
- Convenient in-line servicing with top access cover and no special tools required
- Easy check valve servicing with captured springs
- Lockable ball valves and tamper proof test cocks
- Low pressure drop flow passage
- Durable bronze body with PN16 rating
- Watermark approved for AS/NZS 2845.1 (Device) and WMTS-012 (Ball Valves)

Technical Specification

- Connection Standard: DN15-DN50 BSP
- Temperature Range: 0.5-80°C
- Maximum Working Pressure: 1600 kPa (16 bar)
- Working Medium: Non-corrosive liquids

⚠ WARNING

Device must not be operated outside of the specified limits above to prevent malfunction or damage.

Installation Guide

General

- The backflow assembly must always be installed by a certified installer according to local standards and regulations.
- The assembly needs to be easily accessible to facilitate inspection, testing and servicing. Ensure that isolation handles and test cocks are easily accessible.
- The device must be installed in a horizontal orientation with the body aligned with direction of flow as indicated by flow arrow on the device.
- Always flush pipes before connecting the device and do not apply heat to the device during installation.
- The device should be protected from water hammer and from excessive back pressure caused by thermal expansion or other sources.
- The device should be fitted with a line strainer except when the device is used in a fire system which has infrequent use. The Flomatic Plus RPZ Kit comes with an integrated Ball Valve and Strainer for convenience, which must be fitted to the inlet of the device.
- Two or more backflow assemblies may be installed in parallel to serve higher flow rate demands, or to provide redundancy where continuous water supply is essential during device shutdown.

Location

- The device must not be located in a corrosive environment and be protected against freezing or submerging.
- The device must not be buried in the ground. If installed in a cabinet or pit, sufficient drainage must be fitted.
- Install the device as close as practicable to the point of connection and downstream of any water meter.
- Position the device so that any leakage from discharge vent is readily visible. Do not install in a concealed location.

Specific Requirements

- The discharge vent must always have free ventilation to the atmosphere.
- Water discharge from the relief valve should be vented in accordance with code requirements. The relief valve should never be solidly piped into a drainage ditch, sewer, or sump.
- The discharge should be terminated at least 300mm above the ground or through an air gap piped to a floor drain, as shown in Figure 1.
- Do not reduce the size of the drain line from the air gap fitting, continue drain with full pipe size.

Relief Valve Discharge

- A drain line installed with an air gap terminating above a floor drain will handle any normal discharge or nuisance spitting through the relief valve. However, the floor drain size may need to be designed to prevent water damage caused by a catastrophic failure condition. For technical assistance, contact your local Watts representative.
- Periodic relief valve discharge may occur on dead end service applications, due to fluctuating supply pressure during a static or no flow condition. To avoid this discharge, install a spring-

loaded rubber seated check valve ahead of the backflow assembly to “lock-in” the downstream pressure.

- The relief vent discharges water when, during no-flow periods, the first check valve is fouled or the inlet pressure to the device drops sufficiently due to upstream pressure fluctuations to affect the required operating differential between the inlet pressure and reduced pressure zone. Otherwise, such relief (spitting) can occur when the second check is fouled during emergency backflow or resulting from a water hammer condition.

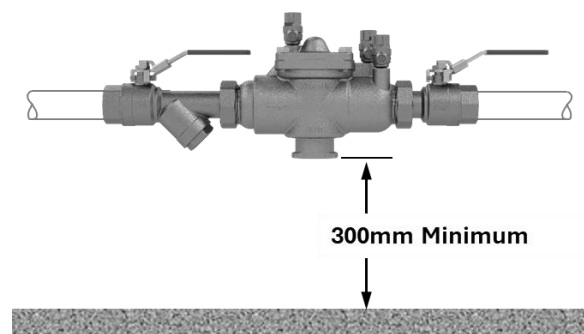

Figure 1: Minimum clearance to discharge vent

Annual Inspection

Annual inspection of all water system safety and control valves is required. Regular inspection, testing, and cleaning ensures proper product function and maximum life of the device. Figure 4 shows the primary components in the RPZ device.

- Testing for proper operation of the device should be made periodically in compliance with AS/NZS 2845.3 and/or local codes, but at least once a year or more often, depending upon system conditions.
- The backflow device must be inspected periodically for any discharge from the relief valve which provides a visual indication of need for cleaning or repair of check valves.
- Inspect the device for signs of leaking or corrosion.
- Close the isolation valves and remove the strainer filter, clean and replace. Check the isolation valves remain operational and recommence supply following the Start Up procedure.
- Refer to the Check Valve or Relief Valve Servicing Procedures if required.

RPZ Kit Assembly

- The RPZ kit assembly comes with union ball valves for easy installation and replacement. The inlet ball valve has an integrated strainer to reduce the plumbing connections and potential leak points.

⚠ WARNING

All O-rings should be lubricated with food grade or AS/NZS 4020 approved 100% silicone grease only.

- Fit the combined ball valve-strainer to the inlet of the device and the ball valve on the outlet, as shown in Figure 2. Ensure that the O-ring's between the device and the ball valve are clean and lubricated before assembly.
- To assemble the device with different fittings, the appropriate adaptor set must be fitted to the inlet and outlet as shown in Figure 3. Refer to the part list at the end of this manual.

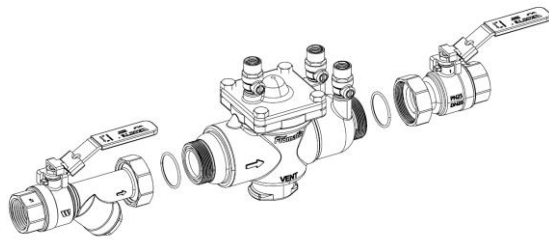

Figure 2: Assembly of RPZ Device with union ball valve and strainer

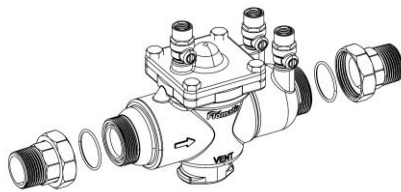

Figure 3: Assembly of RPZ Device with BSP adapters

Start Up Procedure

⚠ WARNING

Ensure the device is protected from shock or water hammer during start up and operation.

- Ensure all three test cocks are closed by turning with a screwdriver to a horizontal position.
- The downstream shutoff should be closed. Open the upstream shutoff slowly and fill the valve. When the valve is filled, open the downstream shutoff slowly and fill the water supply system. This is necessary to avoid water hammer or shock damage.
- Vent air from the device by briefly opening each of the three test cocks. Check the device and connections for leaks. Tighten joints, clean or replace seals if necessary.
- After initial installation, a discharge from the relief valve opening may occur due to inadequate initial flushing of pipelines to eliminate dirt and pipe compounds. If flushing does not clear, remove the first check valve and clean thoroughly.

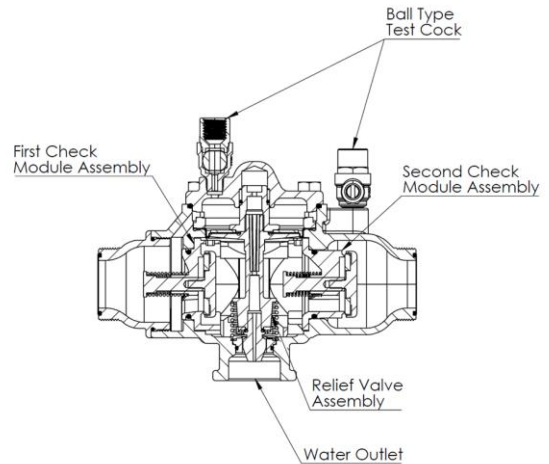

Figure 4: Cross Section View of the RPZ Device

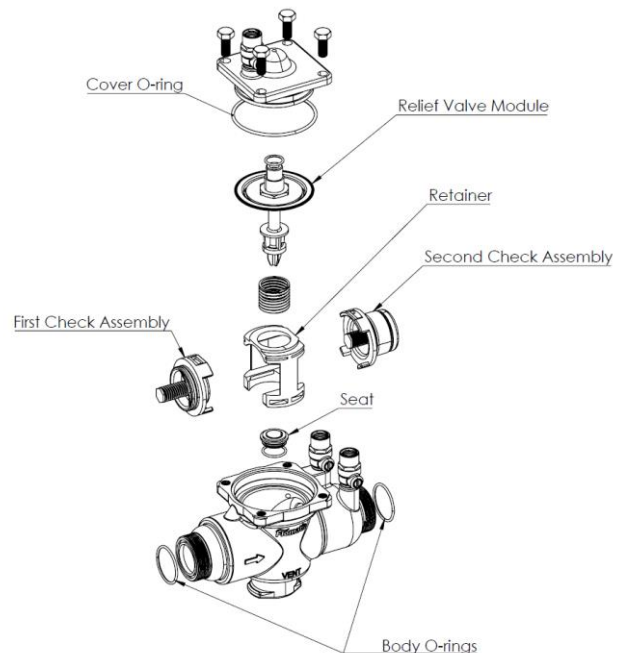

Figure 5: Exploded View of the RPZ Device

Relief Valve Servicing

Follow the following steps to inspect and service the relief valve, referring to components in Figure 5. No special tools are required to disassemble and service the valve.

⚠ WARNING

All O-rings should be lubricated with food grade or AS/NZS 4020 approved 100% silicone grease only.

1. Notify any occupants of the temporary shut-off to water supply. Close the inlet and outlet isolation valves. Relieve internal pressure from the valve by opening all three test cocks by turning with a screwdriver.
2. Remove the four bolts from the top access cover while holding the cover down.

⚠ WARNING

The relief valve mechanism is spring loaded. Hold the cover down when removing the bolts to avoid injury or damage.

3. Lift the cover straight up to remove. The relief valve module will normally remain with the cover as it is removed.
4. Remove the relief valve module from the cover. The rubber diaphragm and washer can be cleaned without disassembling from the stem. Clean the sealing O-ring, rubber diaphragm and rubber washer and inspect for damage or signs of wear.
5. The relief valve spring will remain free inside the body. Remove the spring and retainer, clean if necessary and set aside.
6. The relief valve seat is located at the bottom of the body bore. Check the seat for debris and, if necessary, remove for cleaning by pressing from underneath the valve body. Check the O-ring is clean and lubricated and press the seat firmly back into the body.
7. If any relief valve components are damaged, replace using a suitable repair kit from the Parts List.
8. Before reassembling the relief valve, it is recommended to also inspect and service the check valves by following the steps in Check Valve Servicing section.
9. To reassemble the relief valve, reinstall the retainer and place the spring over the centre of the seat. Lubricate the relief valve module O-ring and reassemble to the cover. Check the cover O-ring is assembled, clean and lubricated. Lower the cover and relief valve module together slowly into the bore. Press down on the cover to ensure proper alignment.

⚠ WARNING

If the cover does not press flat against the body, the stem assembly is crooked and damage can result. Realign the stem, spring and cover before assembling the bolts.

10. Reassemble the four bolts into the cover and check they are securely tightened. Close the three test cocks.
11. Follow the Start Up Procedure section to resume operation.

Check Valve Servicing

Follow the following steps to inspect and service the check valves, referring to components in Figure 5. No special tools are required to disassemble and service the valve.

⚠ WARNING

All O-rings should be lubricated with food grade or AS/NZS 4020 approved 100% silicone grease only.

1. Remove the relief valve assembly by following the steps in the Relief Valve Servicing section.
2. After removing the retainer from the body bore. The check valve modules can be removed by hand or with a flat head screwdriver.

⚠ WARNING

Note the first and second check. The seats and springs of the first and second check modules are not interchangeable. The heavier spring and smaller seat belong with the first check module, which is installed on the inlet side of the valve.

3. Inspect the plastic seat and O-ring on each check valve for debris or damage.
4. Inspect the rubber disk for damage. If necessary, replace the check valve with a suitable repair kit from the Parts List.
5. Clean all components and flush the valve body. Lubricate the O-rings and reassemble the check valve modules with the spring side pointing towards the inlet. Reinstall the retainer. The modules must be inserted fully for the retainer to fit.
6. Follow the remaining steps the Relief Valve Servicing section to finish the reassembled and Start Up of the device.

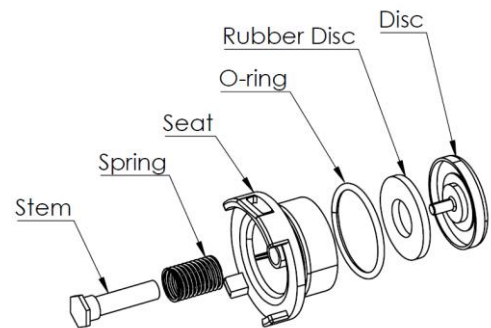

Figure 6: First Check Assembly

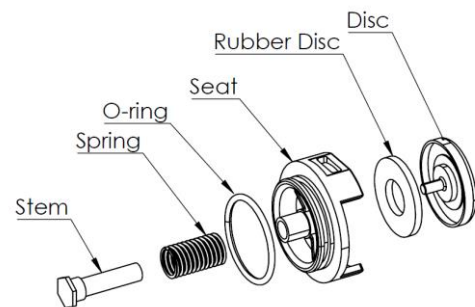
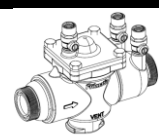
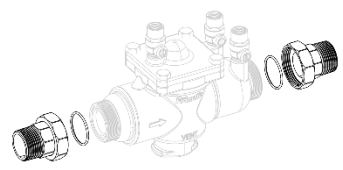
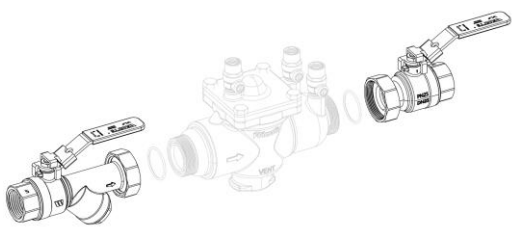
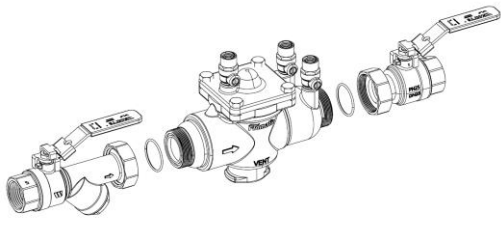





Figure 7: Second Check Assembly

Flomatic Plus RPZ Parts List

ORDER CODE	PRODUCT CODE	DESCRIPTION	IMAGE
61130219	PP-FLO-RPZ-15-20-25	RPZ device only for DN15/20/25 (needs Adaptor Set or Ball Valve kit)	
61130225	PP-FLO-RPZ-32-40-50	RPZ device only for DN32/40/50 (needs Adaptor Set or Ball Valve kit)	
61132158	PP-FLO-DCV-RPZ-015-ADPT	DN15 adaptor set for DCV or RPZ device	
61132159	PP-FLO-DCV-RPZ-020-ADPT	DN20 adaptor set for DCV or RPZ device	
61132160	PP-FLO-DCV-RPZ-025-ADPT	DN25 adaptor set for DCV or RPZ device	
61132161	PP-FLO-DCV-RPZ-032-ADPT	DN32 adaptor set for DCV or RPZ device	
61132162	PP-FLO-DCV-RPZ-040-ADPT	DN40 adaptor set for DCV or RPZ device	
61132163	PP-FLO-DCV-RPZ-050-ADPT	DN50 adaptor set for DCV or RPZ device	
61130220	PP-FLO-ULBS-15-FIT-KIT	DN15 union ball valve kit for DCV or RPZ device (BV and BV+Strainer)	
61130221	PP-FLO-ULBS-20-FIT-KIT	DN20 union ball valve kit for DCV or RPZ device (BV and BV+Strainer)	
61130222	PP-FLO-ULBS-25-FIT-KIT	DN25 union ball valve kit for DCV or RPZ device (BV and BV+Strainer)	
61130226	PP-FLO-ULBS-32-FIT-KIT	DN32 union ball valve kit for DCV or RPZ device (BV and BV+Strainer)	
61130227	PP-FLO-ULBS-40-FIT-KIT	DN40 union ball valve kit for DCV or RPZ device (BV and BV+Strainer)	
61130228	PP-FLO-ULBS-50-FIT-KIT	DN50 union ball valve kit for DCV or RPZ device (BV and BV+Strainer)	
61130157	PP-FLO-RPZ-015-ULBS	DN15 RPZ kit with device and ball valve kit	
61130158	PP-FLO-RPZ-020-ULBS	DN20 RPZ kit with device and ball valve kit	
61130159	PP-FLO-RPZ-025-ULBS	DN25 RPZ kit with device and ball valve kit	
61130160	PP-FLO-RPZ-032-ULBS	DN32 RPZ kit with device and ball valve kit	
61130161	PP-FLO-RPZ-040-ULBS	DN40 RPZ kit with device and ball valve kit	
61130162	PP-FLO-RPZ-050-ULBS	DN50 RPZ kit with device and ball valve kit	
61132209	PP-FLO-RPZ-15-25-CK1	First Check Valve for DN15/20/25 RPZ	
61132210	PP-FLO-RPZ-32-50-CK1	First Check Valve for DN32/40/50 RPZ	
61132211	PP-FLO-RPZ-15-25-CK2	Second Check Valve for DN15/20/25 RPZ	
61132212	PP-FLO-RPZ-32-50-CK2	Second Check Valve for DN32/40/50 RPZ	
61132213	PP-FLO-RPZ-15-25-RV	Relief Valve Repair Kit for DN15/20/25 RPZ	
61132214	PP-FLO-RPZ-32-50-RV	Relief Valve Repair Kit for DN32/40/50 RPZ	
61132209	PP-FLO-RPZ-15-25-T	Total Repair Kit for DN15/20/25 RPZ (Includes First Check, Second Check, Relief Valve, Spring and Seat)	
61132210	PP-FLO-RPZ-32-50-T	Total Repair Kit for DN32/40/50 RPZ (Includes First Check, Second Check, Relief Valve, Spring and Seat)	

Contact your local Watts representative or Wattsau.com.au for more information.

Troubleshooting

Troubleshooting and repairs of a backflow device should be performed by trained and authorised personnel only.

PROBLEM	CAUSE	SOLUTION
Continuous discharge from vent	Fouled internal component	Close the outlet isolation valve. If the discharge stops, the Second Check Valve needs servicing. If the discharge continues, open the test cock on the outlet of the device. If the discharge stops, the first check valve needs servicing. If the discharge continues, the Relief Valve needs servicing.
	Excessive backpressure, freezing, or water hammer has distorted the second check.	Eliminate source of excessive backpressure or water hammer in the system downstream of the device. Replace defective second check assembly. In case of freezing; thaw, disassemble, and inspect internal components. Replace as necessary.
	Electrolysis of relief valve seat	Replace relief valve seat. Install dielectric unions. Electrically ground the piping system and/or electrically isolate the device with plastic pipe immediately upstream and downstream of the device.
	Valve improperly reassembled	If valve has been disassembled, caution must be exercised to follow instructions correctly and ensure check valves are installed in correct position.
Valve spits periodically from the vent	Fluctuating supply pressure	Check function of upstream Pressure Reducing Valve (PRV) or install one if it is not present. If problem persists, install a soft seated spring check valve immediately upstream of the device.
	Fluctuating downstream pressure.	Install a soft seated spring check valve downstream of the device as close as possible to the shutoff valve.
Valve exhibits high pressure drop	Fouled strainer	Clean strainer or replace.
	Valve size too small for required flow rate	Install proper size device based on flow requirements.
No water flows downstream of valve	Isolation valves are closed	Open isolation valves
	Valve installed backwards	Install valve in accordance with flow direction arrow
Valve does not test properly	Leaky downstream isolation valve	Clean or replace isolation valve
Valve quickly and repeatedly fouls following servicing	Debris in pipeline is too fine to be trapped by strainer.	Install finer mesh strainer element in the strainer and/or install additional strainer prior to the device.

Limited Warranty: Watts (the "Company") warrants each product to be free from defects in material and workmanship under normal usage for a period of one year from the date of delivery. In the event of such defects within the warranty period, the Company will, at its option, replace or recondition the product without charge.

THE WARRANTY SET FORTH HEREIN IS GIVEN EXPRESSLY AND IS THE ONLY WARRANTY GIVEN BY THE COMPANY WITH RESPECT TO THE PRODUCT. THE COMPANY MAKES NO OTHER WARRANTIES, EXPRESS OR IMPLIED. THE COMPANY HEREBY SPECIFICALLY DISCLAIMS ALL OTHER WARRANTIES, EXPRESS OR IMPLIED, INCLUDING BUT NOT LIMITED TO THE IMPLIED WARRANTIES OF MERCHANTABILITY AND FITNESS FOR A PARTICULAR PURPOSE.

The remedy described in the first paragraph of this warranty shall constitute the sole and exclusive remedy for breach of warranty, and the Company shall not be responsible for any incidental, special or consequential damages, including without limitation, lost profits or the cost of repairing or replacing other property which is damaged if this product does not work properly, other costs resulting from labor charges, delays, vandalism, negligence, fouling caused by foreign material, damage from adverse water conditions, chemical, or any other circumstances over which the Company has no control. This warranty shall be invalidated by any abuse, misuse, misapplication, improper installation or improper maintenance or alteration of the product.