

MICRON WH303A

CLASSIC 300 SERIES - TRIPLE WHOLE HOUSE FILTRATION SYSTEM

General Information

The WH303A Classic 300 Series is a point-of-entry filtration system designed to deliver reliable, whole house protection. Engineered with a UV-protected 316-grade stainless steel cover, it's built to withstand Australia's harsh environment while maintaining long-lasting performance.

This system filters down to 5 microns, effectively reducing sediment, chlorine, THMs, VOCs, and PFAS "Forever Chemicals" – improving taste, odour, and overall water quality. Featuring a specialised carbon PFAS reduction filter, it provides added protection against emerging contaminants for cleaner water.

Ideal for budget-conscious households, the Classic 300 Series offers an affordable and dependable solution for better living. Enjoy improved skin and hair health, enhanced wellbeing, and peace of mind knowing your water is cleaner, fresher, and healthier for the whole family.

Designed for mains water supply.



Features and Benefits

- Connection design ensures 100% of water flows through the filter media, allowing for maximum contact time and more effective contaminant reduction
- Standard 4.5" x 20" housings provide double the capacity of 4.5" x 10" housings
- Greater contact time, flow rates, longevity, and chemical removal
- Suitable for small to large homes with 2 or more bathrooms
- 5 micron PP Sediment Pre-Filter removes fine particles, sand, and rust
- Granular Activated Carbon (GAC) Filter with excellent absorption capacity of dissolved organics and chemicals such as chlorine and THMs, improving colour, taste, and odour
- A specialised carbon block PFAS reduction filter removes PFAS and other contaminants, enhancing water taste and quality
- UV resistant marine grade 316 stainless steel brackets and external cover
- ¼" top mount pressure gauge ports and bleed valve

Cartridge Replacement and Timeframe Suggestions

WH20-5SED 5 micron PP Sediment Filter cartridge to be replaced every 3 - 6 months.

WH20-GAC Coconut Shell Granular Activated Carbon Filter cartridge to be replaced every 6 - 12 months.

WH20-PFAS Carbon PFAS Reduction 5 micron Filter cartridge to be replaced every 6 - 12 months.

Version 2_Feb 2026

MICRON WH303A

CLASSIC 300 SERIES - TRIPLE WHOLE HOUSE FILTRATION SYSTEM

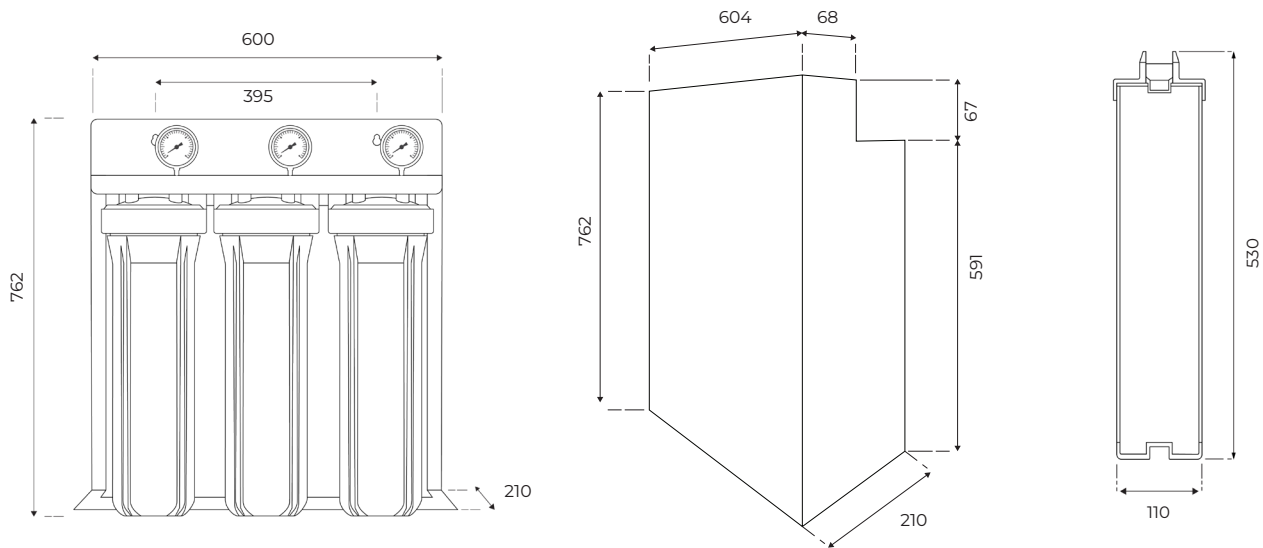

Measurements in millimetres

Classic 300 Series Specifications

Model	WH303A
Product Description	Classic 300 Series - Triple Whole House Filtration System 1st stage: 5 micron PP Sediment Pre-Filter (Model: WH20-5SED) 2nd stage: Granular Activated Carbon Filter (Model: WH20-GAC) 3rd stage: Carbon PFAS Reduction Filter (WH20-PFAS)
Filtration Capacity	Removes dirt, sand, silt, rust and fine particles to nominal size. Reduces chlorine, PFAS, VOCs, chemicals, odour, and unpleasant taste.
Flow Rate	35L/min
Micron Rating	5 micron*
Min/Max Pressure	200-1600 kPa (with PLV)
Min/Max Temperature	4 - 42°C (must not freeze / cold water only)
Connection	Standard Port Size 1" - Brass Thread
External Cover	316 Marine Grade Stainless Steel Mounting Frame and Cover
Cartridge Size	4.5" x 20"
Compatible Filter Cartridges	WH20 Filter Series
Dimensions	With Cover: 762 mm (H) x 604 mm (L) x 210 mm (W)
Certification	WaterMark
Warranty	3 Years [^]

[^] 3 year warranty covering parts only, excluding cartridges. Use only genuine Micron Water Filters cartridges. Filter replacement timeframes are guidelines only and may vary with water quality and usage.

* Micron rating is nominal.