

MICRON WH302

TWIN WHOLE HOUSE FILTRATION SYSTEM

General Information

The WH302 is a Point of Entry Filtration System, mounted on a robust stainless steel hanging bracket for long-lasting durability. Designed for mains water supplies, it delivers dependable, whole-of-house filtration down to 5 microns—effectively reducing sediment, chlorine, and chlorine by-products such as THMs and VOCs to enhance taste and odour.

Featuring a specialised seal design that prevents water bypass and ensures full media contact, the WH302 provides reliable, great-tasting water for your entire home or business.

For mains water supply.



Features and Benefits

- High flow twin filtration for both commercial and residential use
- Standard size 4.5" x 20" housings — providing 100% more capacity than 4.5" x 10"
- Greater contact time, flow rates, longevity and chemical removal
- Suitable for small to large homes with 2 or more bathrooms
- 5 micron Sediment Pre-Filter removes larger particles like sand, dirt, rust, and debris from the water
- CTO Carbon Block Filter removes chlorine, volatile organic compounds (VOCs), pesticides, herbicides and other chemicals, improving taste and odour
- Stainless Steel mounting bracket
- Brass thread connection
- ¼" top mount pressure gauge ports and bleed valve

Cartridge Replacement and Timeframe Suggestions

WH20-5SED 5 micron PP Sediment Filter cartridge to be replaced every 6 - 12 months.

WH20-CTO Coconut Shell Carbon Block Filter to be replaced every 6 - 12 months.

Version 1_Apr 2025

MICRON WH302

TWIN WHOLE HOUSE FILTRATION SYSTEM

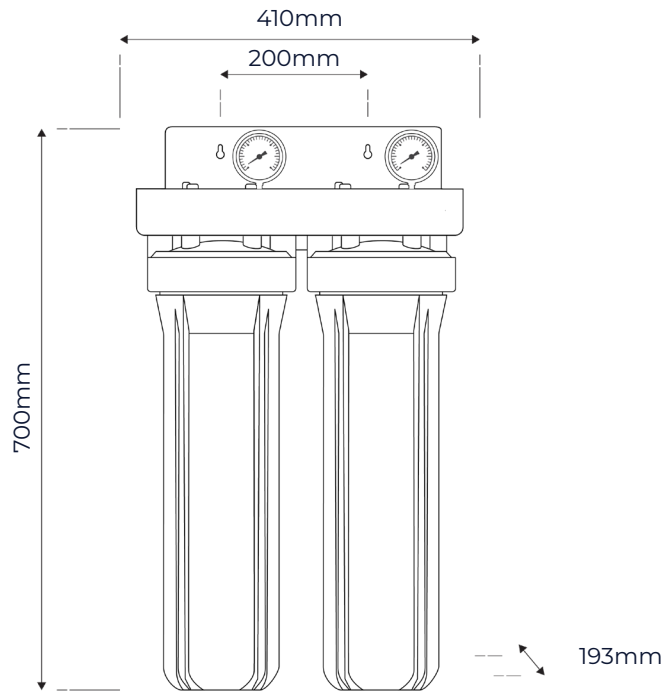

Measurements in millimetres

Twin Whole House Filtration Specifications

Model	WH302
Product Description	Twin Whole House Filtration System 1st stage: 5 micron PP Sediment Pre-Filter (Model: WH20-5SED) 2nd stage: CTO Coconut Shell Carbon Block Filter (Model: WH20-CTO)
Filtration Capacity	Removes dirt, sand, silt, rust and fine particles to nominal size Reduces chlorine, VOCs, chemicals, odour and unpleasant taste
Flow Rate	35L/min
Micron Rating	5 micron*
Min/Max Pressure	200-1600 kPa
Min/Max Temperature	4 - 42°C (must not freeze / cold water only)
Connection	Standard Port Size 1" - Brass Thread
External Cover	Stainless Steel mounting bracket
Cartridge Size	4.5" x 20"
Compatible Filter Cartridges	WH20 Series
Dimensions	410 mm (W) x 193 mm (D) x 700 mm (H)
Certification	WaterMark
Warranty	3 Years [^]

[^] 3 year warranty covering parts only, excluding cartridges. Use only genuine Micron Water Filters cartridges. Filter replacement timeframes are guidelines only and may vary with water quality and usage.

* Micron rating is nominal.