

MICRON RO-301B

3 STAGE UNDERSINK REVERSE OSMOSIS

General Information

The Micron Undersink RO Series – RO-301B combines space efficiency, user-friendly design, and advanced technology to deliver pure RO water, enhanced with a GAC & Mineral filter for optimal remineralisation of essential minerals. Designed for optimal space-saving, it features practical enhancements like quick filter changes and an intelligent IC controller, ensuring a smooth and efficient water filtration experience.

The intelligent IC controller features 24/7 TDS detection, automatic filter replacement notifications, and leak detection, empowering users with easy setting adjustments, continuous water quality monitoring, and timely filter change alerts. This advanced technology ensures constant access to clean, purified water while giving you full control over the system's functionality, supporting your family's health and wellbeing.

Designed for mains water supply.



Features and Benefits

- Undersink 3 Stage Micro-Computer Controller Reverse Osmosis Water Filtration Unit with booster pump
- Stylish sleek compact design with LED control panel
- Micro-computer with automatic 24 hr water quality TDS detection, filter replacement alerts, and leak detection
- High loop chrome plated faucet
- Easy, quick-twist change filter cartridges
- 5 micron PP Sediment & CTO Carbon Block Pre-Filter for removal of fine particles and chlorine
- RO membrane filters down to 0.0001 microns*, effectively removing up to 99%** of Total Dissolved Solids (TDS), Volatile Organic Compounds (VOCs), chemicals (ie PFAS), fluoride, chlorine, heavy metals, viruses, bacteria, parasites, lead, pesticides, and herbicides
- The final stage includes our Mineral Filter using a combination of GAC & Maifan Stone to add essential minerals
- 3L internal pressure tank

Reverse Osmosis Systems flush away impurities, producing both pure product water and reject water at a typical 1:3 ratio. While reject water is usually drained, it can be repurposed for gardening.

For efficiency and sustainability, the Micron RO system features a built-in shut-off valve that stops water production when the storage tank is full, reducing waste.

Cartridge Replacement and Timeframe Suggestions

MRS-PC 5 micron PP Sediment & CTO Carbon Block Filter cartridge to be replaced every 3 - 6 months.

MRS-RO50 RO Membrane Filter cartridge to be replaced every 75ppm or 24 - 36 months.

MRS-34M GAC & Mineral Filter cartridge to be replaced every 12 months.

Version 2_June 2025

MICRON RO-301B

3 STAGE UNDERSINK REVERSE OSMOSIS

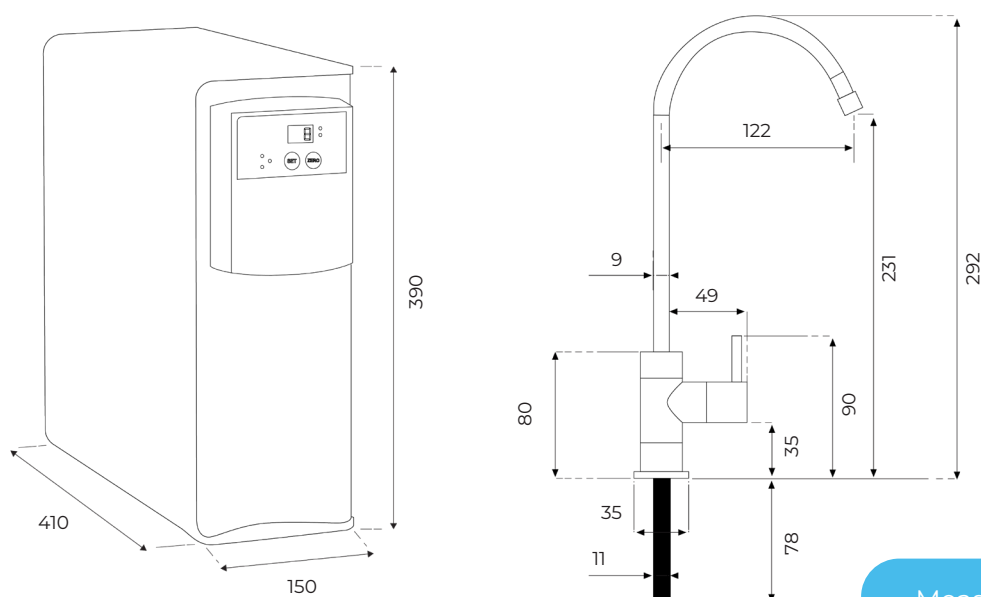

Measurements in millimetres

3 Stage RO Undersink Series Specifications

Model	MRS-ROU-301B
Product Description	3 Stage Reverse Osmosis Undersink System Stage 1: 5 micron PP Sediment & CTO Carbon Block Pre-Filter (Model: MRS-PC) Stage 2: RO Membrane Filter (Model: MRS-RO50) Stage 3: GAC & Mineral Filter (Model: MRS-34M)
Filtration Capacity	Eliminates up to 99%** of contaminants, including Total Dissolved Solids (TDS), fluoride, chlorine, chemicals (ie PFAS), heavy metals (ie lead), viruses, bacteria, parasites, pesticides, herbicides, sediment, turbidity, odour and bad taste
Flow Rate	0.13L/min
Micron Rating	0.0001 micron*
Min/Max Pressure	100 - 550 kPa
Min/Max Temperature	4 - 42°C (must not freeze / cold water only)
Connection	1/4" Quick Connect
Daily Production	190 LPD (1:3 RO/Waste Water Ratio)
Faucet	Chrome Plated High Loop Faucet (12.5 mm hole)
Booster Pump	Yes
Storage Tank	Internal Pressurised Tank 3L Capacity, NSF Certified
Cartridge Size	7" Quick-Change
Compatible Filter Cartridges	MRS Quick-Change Cartridge Series
Dimensions	390 mm (H) x 150 mm (L) x 410 mm (W)
Certification	WaterMark
Warranty	2 Years [^]

[^] 2 year warranty covering parts only, excluding cartridges. Use only genuine Micron Water Filters cartridges. Filter replacement timeframes are guidelines only and may vary with water quality and usage.

* Micron rating is nominal.

** Dependent on the quality and characteristics of the water.