



Soho 800mm Double Towel Rail

Product Image



Product Details

Code: TVA3362361 (Chrome)
 TVA3362395 (Matte Black)
 TVA3362385 (Brushed Gold)
 TVA3362380 (Brushed Nickel)
 TVA3362390 (Gun Metal)

Brand: Villeroy & Boch
Range: Soho
Warranty: 5 Years*

Additional Features

Required Product

Recommended Products

Additional Notes

- Round Backing Flange & Soft Square Backing Flange included
- Triple Fixing

Technical Specification

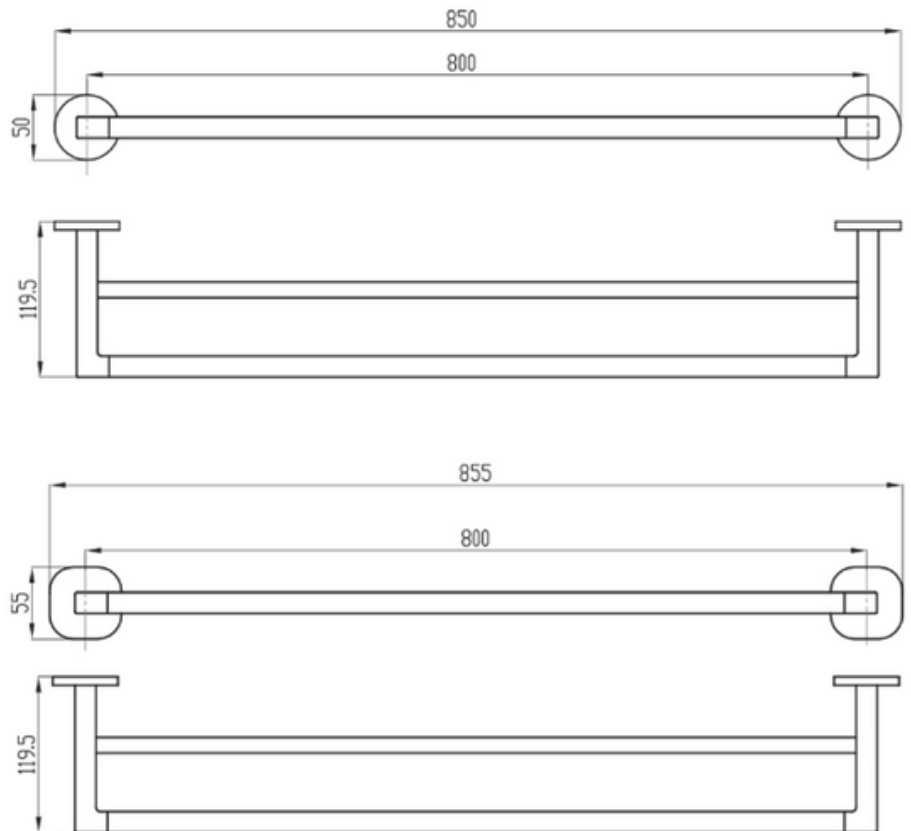

*Please visit argentaust.com.au/warranty to view the full warranty

Note: All dimensions are in millimetres and are subject to normal manufacturing variations. Always use the physical product measurements for cut-outs and rough-ins as the technical details shown may differ from the actual product. Use acetic cured silicone sealant. Do not use epoxy type adhesives. Clean with damp cloth. Do not use abrasive cleaners, liquids or pastes.