

CONVERTING TO BATH FILLER:

Remove Basin Aerator from the outlet with the aerator key. Install Free Flow Aerator to the outlet.

Apply Teflon Tape to Threaded Elbow.
 Make sure that O-Rings are seated in the grooves of the G1/2" adaptor.
 Screw the G1/2" adaptor onto Threaded Elbow firmly with a spanner.
 Push the spout assembly onto the G1/2" adaptor.
 Fasten Grub Screw using the Allen Key Provided.

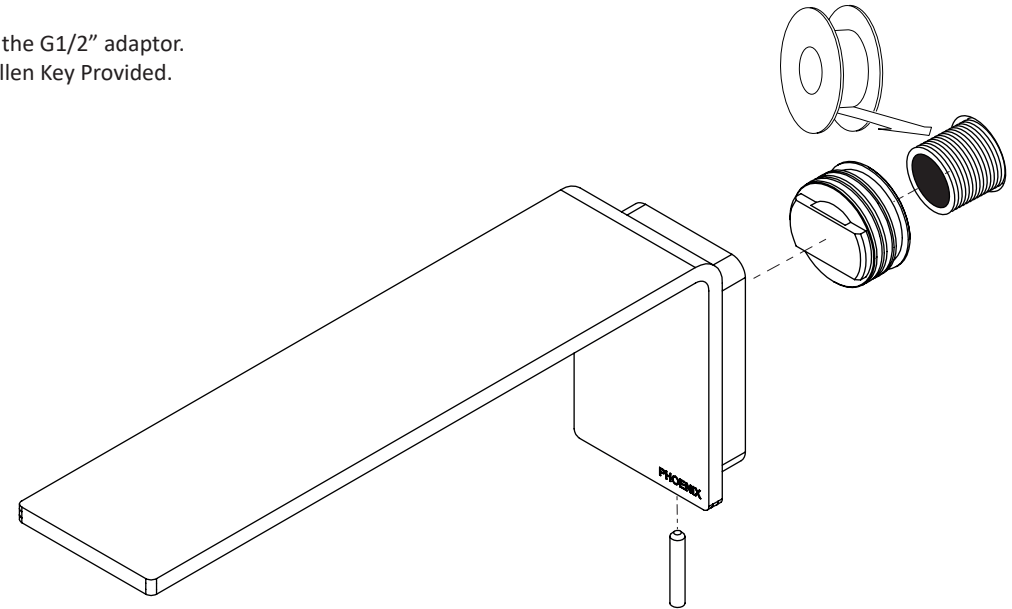

recommended working pressure
150-500KPa
 maximum hot water temperature
75 degrees



NOTE:

- If the pressure exceeds or is likely to exceed 550kpa, an approved pressure limiting device must be installed.
- Flush out all pipe work prior to installation.
- If the water temperature exceeds 75°C, an approved tempering valve must be fitted.
- Installation should comply with Australian standard AS3500.1 or relevant local authority requirements. Showers may not be suitable for use within:
 - Gravity-fed water systems

- Some instantaneous hot water systems; or
 - Pressure supply less than 150kPa;
- NOTE: The 500kPa maximum water supply pressure does not apply to fire service outlets.

Failure to comply with the above may void all warranties.

WARRANTY:

Please refer to the full warranty statement enclosed with the product before installing.

MAINTENANCE AND CARE:

- Chrome plated surfaces should be cleaned with mild liquid detergent or soap and water.
- Do not use cream cleaners or citrus based cleaning products, as they are abrasive.
- Use of unsuitable cleaning agents may damage the surface. Any damage caused in this way will not be covered by warranty.

DISCLAIMER:

While we aim to ensure the specifications shown are correct at the time of printing, we reserve the right to make modifications without prior notice. Always use the physical product measurements for mark-ups and roughing-in as the line drawing shown may differ from the actual product over time.

*All measurements are shown in millimeters.