

**BREACH SET-UP:**

Total adjustment range measured from Nogging to finished wall surface is 55mm to 68mm.

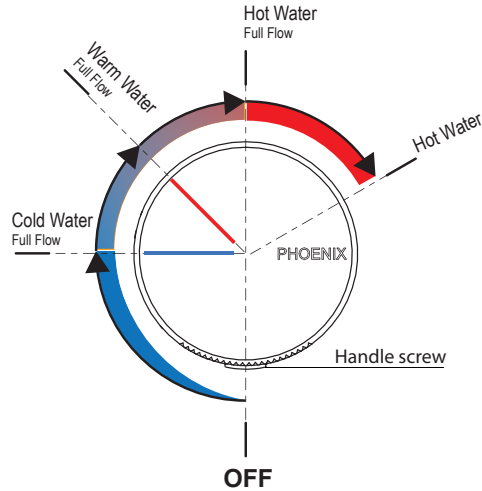
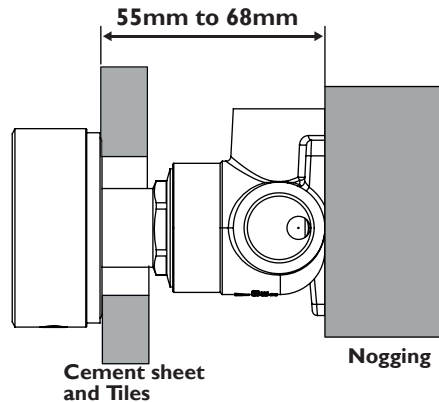

**1**

Mount the Mixer Body in place using the wood screws provided. Ensure that Mixer Body is level.

Connect water supply and water outlet.  
Test and check for leaks.

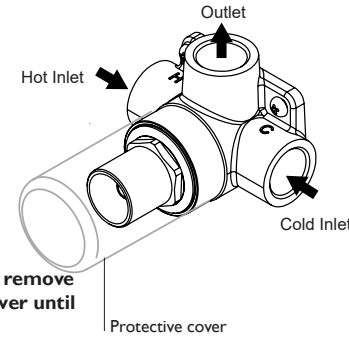

**Note: Do not remove protective cover until final fit-off.**

**2**

Create a 45mm round hole in cement sheet and tiles.

Remove the protective cover.

**Turn the spindle Anti-Clockwise with Spindle Adaptor until the cartridge is set to OFF position.**

Remove Spindle Adaptor.

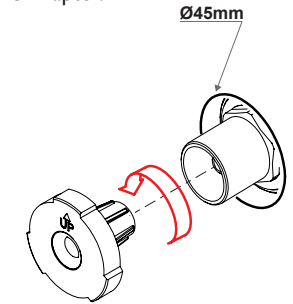

**3**

Ensure there is an O-Ring fitted to the base of the handle assembly.

Place the handle assembly over the mixer body with Red Rubber Indicator pointing vertically downward.

Secure Handle Assembly by tightening Locknut with a 1" Hex tube spanner.

Remove Red Rubber Indicator

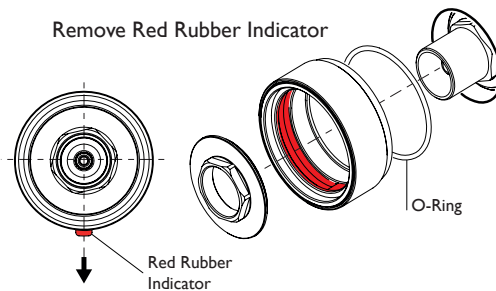

**4**

Ensure there is an O-Ring fitted to the base of the handle assembly.

Place the handle assembly over the mixer body with Red Rubber Indicator pointing vertically downward.

Secure Handle Assembly by tightening Locknut with a 1" Hex tube spanner.

Remove Red Rubber Indicator

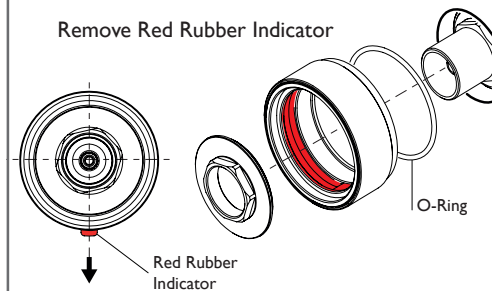

**5**

Fit Spindle Sleeve over the spindle adaptor.

Tighten Handle Screw to secure Spindle Sleeve.

Ensure an O-Ring is attached to Front Cover.

Apply some grease or soapy water to the O-Ring if necessary.

Push Front Cover into Handle Assembly.

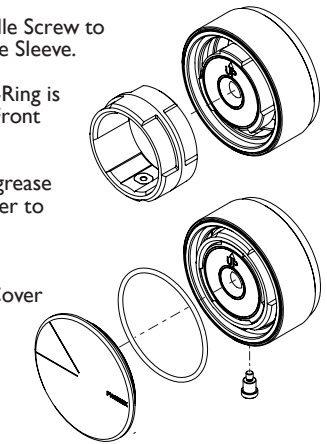

recommended working pressure

**150-500kPa**

maximum hot water temperature



**75 degrees**

**NOTE:**

- If the pressure exceeds or is likely to exceed 550kpa, an approved pressure limiting device must be installed.
- Flush out all pipe work prior to installation.
- If the water temperature exceeds 75°C, an approved tempering valve must be fitted.
- Installation should comply with Australian standard AS3500.1 or relevant local authority requirements. Showers may not be suitable for use within:
  - Gravity-fed water systems

- Some instantaneous hot water systems; or
  - Pressure supply less than 150kPa;
- NOTE: The 500kPa maximum water supply pressure does not apply to fire service outlets.

Failure to comply with the above may void all warranties.

**WARRANTY:**

Please refer to the full warranty statement enclosed with the product before installing.

**MAINTENANCE AND CARE:**

- Chrome plated surfaces should be cleaned with mild liquid detergent or soap and water.
- Do not use cream cleaners or citrus based cleaning products, as they are abrasive.
- Use of unsuitable cleaning agents may damage the surface. Any damage caused in this way will not be covered by warranty.

**DISCLAIMER:**

While we aim to ensure the specifications shown are correct at the time of printing, we reserve the right to make modifications without prior notice. Always use the physical product measurements for mark-ups and roughing-in as the line drawing shown may differ from the actual product over time.

\*All measurements are shown in millimeters.