

Adjustment :

Total adjustment range measured from Noggin to finished wall surface is 42mm to 54mm.

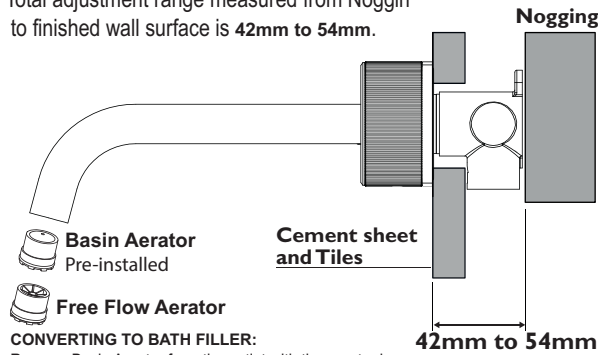

CONVERTING TO BATH FILLER:

Remove Basin Aerator from the outlet with the aerator key. Install Free Flow Aerator to the outlet.

Rough-In :

Screw the wall breach in place. CHECK FOR LEVEL. Connect water supply. TEST & CHECK FOR LEAKS. Create clearance holes in cement sheet and tiles.

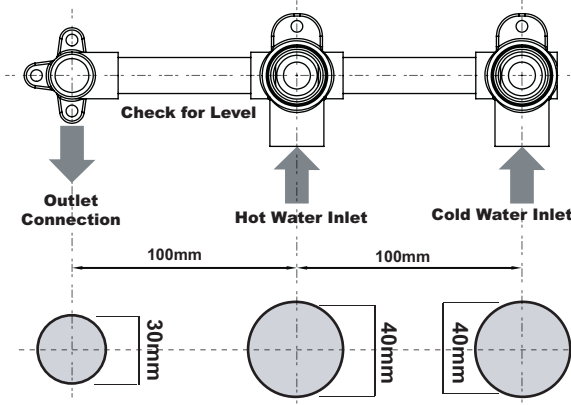

1 Firmly screw the spindle into the breach.
NOTE: DO NOT OVER TIGHTEN

Fit the fibre washer over the spindle and then fasten the bonnet onto the spindle using a spanner.

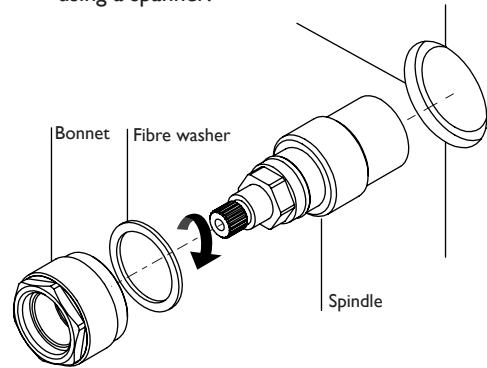

2 Ensure the o-ring is seated in the flange. Screw the flange onto the bonnet until it sits hard up against the finished wall surface.

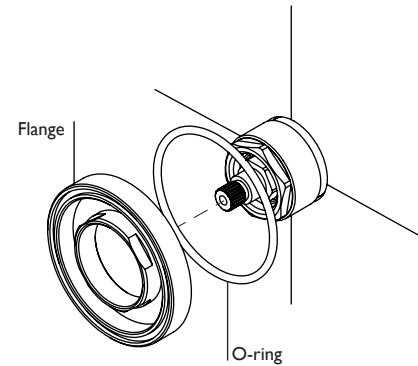

3 Turn the spindle clockwise until the cartridge is set to OFF position.

Fit the spindle adaptor to the spindle. Secure it with the two grub screws as shown.

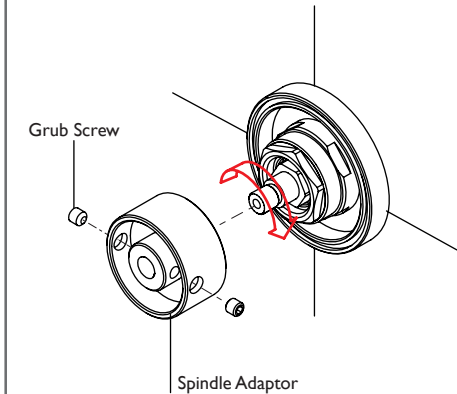

4 Fit the washer into the groove on the flange. Place the handle onto the spindle adaptor and secure it with the grub screw. Fit Rubber Cap.

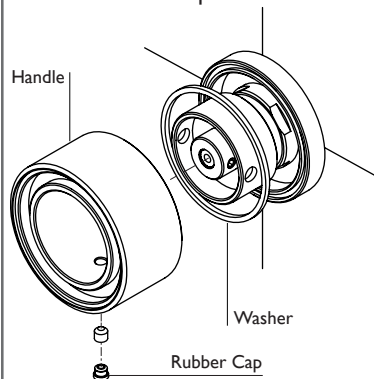

5 Ensure the o-ring is seated on the indicator cover. Apply some grease or soapy water to O-Ring if necessary.

Push the indicator cover into the handle.

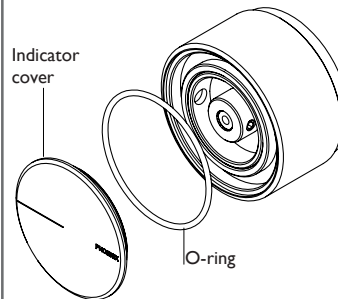

6 Apply teflon tape to the outlet connector. Ensure that O-Ring is fitted to the spout base.

Screw the spout base onto the elbow thread with a spanner. Push the spout onto the spout base.

Fasten Grub Screw. TEST & CHECK FOR LEAKS

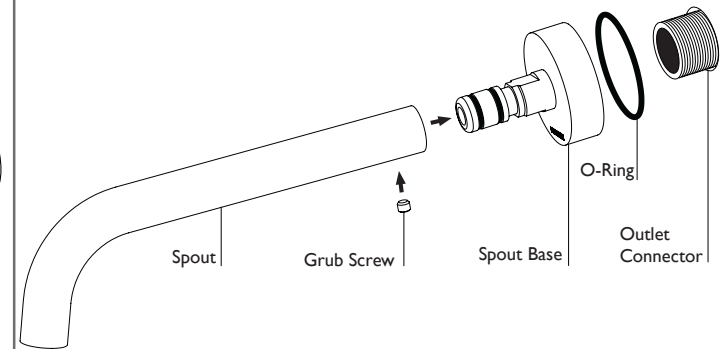

recommended working pressure

150-500kPa

maximum hot water temperature



75 degrees

NOTE:

- If the pressure exceeds or is likely to exceed 550kpa, an approved pressure limiting device must be installed.
- Flush out all pipe work prior to installation.
- If the water temperature exceeds 75°C, an approved tempering valve must be fitted.
- Installation should comply with Australian standard AS3500.1 or relevant local authority requirements. Showers may not be suitable for use within:
 - Gravity-fed water systems

- Some instantaneous hot water systems; or
 - Pressure supply less than 150kPa;
- NOTE: The 500kPa maximum water supply pressure does not apply to fire service outlets.

Failure to comply with the above may void all warranties.

WARRANTY:

Please refer to the full warranty statement enclosed with the product before installing.

MAINTENANCE AND CARE:

- Chrome plated surfaces should be cleaned with mild liquid detergent or soap and water.
- Do not use cream cleaners or citrus based cleaning products, as they are abrasive.
- Use of unsuitable cleaning agents may damage the surface. Any damage caused in this way will not be covered by warranty.

DISCLAIMER:

While we aim to ensure the specifications shown are correct at the time of printing, we reserve the right to make modifications without prior notice. Always use the physical product measurements for mark-ups and roughing-in as the line drawing shown may differ from the actual product over time.

*All measurements are shown in millimeters.