

ADJUSTMENT RANGE

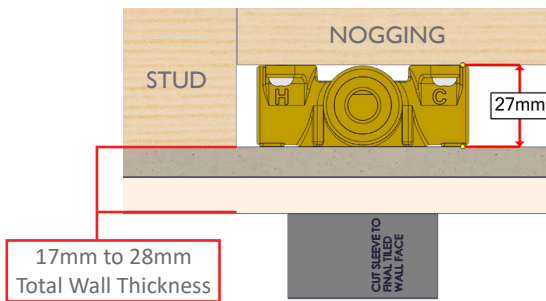

Range from the Nogging face to the Stud Face is 27mm as shown.

Adjustment range from the finished face of the tiles to the stud is 17mm to 28mm as shown.

Check Wall Mixer Lugs are Flush to Stud to allow for installation of sheet and tiles

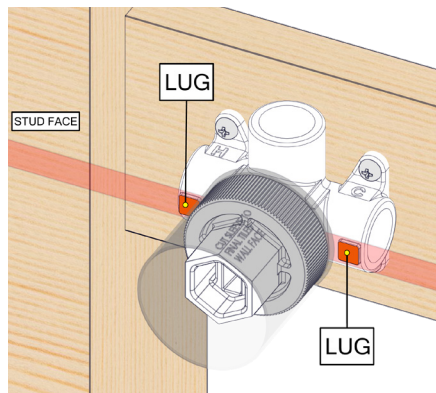

Check Lugs (Highlighted in ORANGE) are Flush with Front of Stud.

1 Screw the Mixer Breach onto Nogging to dimensions shown in adjustment range.

Ensure that the mixer body is level.

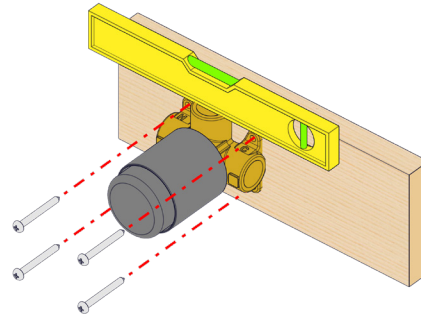

2 Plumb all connections to Mixer Body.

Perform **PRESSURE TEST** and check for leaks.

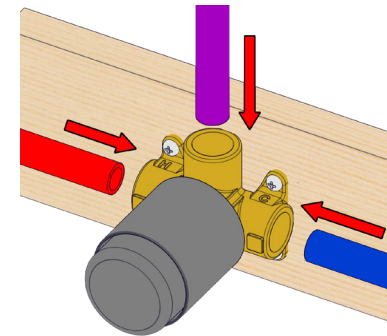

3 Create a 50mm diameter hole in the cement sheet or Plasterboard.

Apply waterproofing membrane up to Waterproofing Sleeve.

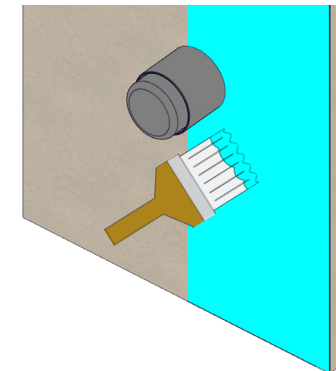

4 After Tiling use Knife to Trim Waterproofing Sleeve flush to Tile face.

Remove Protective Cover.

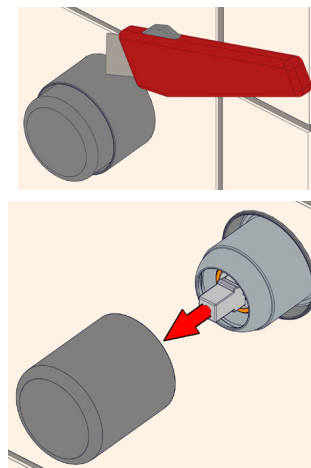

5 Gently Push Dress plate over assembly.

Push Handle onto Cartridge.

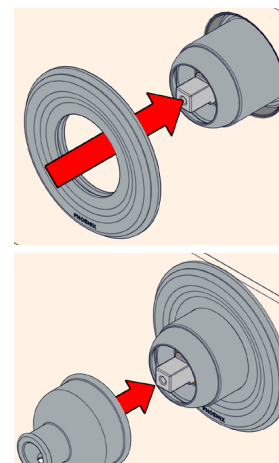

6 Tighten Screw into Cartridge securing Handle.

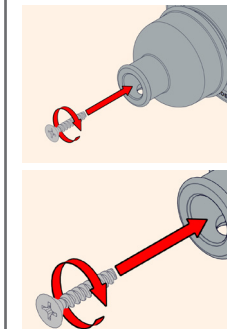

7 Push Handle Cap into position. Ensuring correct orientation.

Tighten Pin into position.

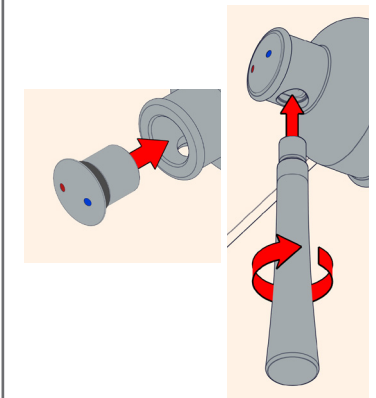

recommended working pressure

150-500kPa

maximum hot water temperature



75 degrees

NOTE:

- If the pressure exceeds or is likely to exceed 550kpa, an approved pressure limiting device must be installed.
- Flush out all pipe work prior to installation.
- If the water temperature exceeds 75°C, an approved tempering valve must be fitted.
- Installation should comply with Australian standard AS3500.1 or relevant local authority requirements. Showers may not be suitable for use within:
 - Gravity-fed water systems

- Some instantaneous hot water systems; or
 - Pressure supply less than 150kPa;
- NOTE: The 500kPa maximum water supply pressure does not apply to fire service outlets.

Failure to comply with the above may void all warranties.

WARRANTY:

Please refer to the full warranty statement enclosed with the product before installing.

MAINTENANCE AND CARE:

- Chrome plated surfaces should be cleaned with mild liquid detergent or soap and water.
- Do not use cream cleaners or citrus based cleaning products, as they are abrasive.
- Use of unsuitable cleaning agents may damage the surface. Any damage caused in this way will not be covered by warranty.

DISCLAIMER:

While we aim to ensure the specifications shown are correct at the time of printing, we reserve the right to make modifications without prior notice. Always use the physical product measurements for mark-ups and roughing-in as the line drawing shown may differ from the actual product over time.

*All measurements are shown in millimeters.